

PCODOS Optical Dissolved Oxygen System



Features & Benefits

Potence Controls PCODOS Optical Dissolved Oxygen System is an excellent choice for an accurate measure in all situation with wide range of applications like Urban wastewater treatment; Industrial effluent treatment ;Surface water monitoring ; Sea water monitoring, Fish farming, Aquarium and Drinking water. The Optical Dissolved Oxygen sensor is based on Luminescent optical technology.

Without calibration requirements with ultra-low power technology, the Optical Dissolved Oxygen sensor meets the demands of field works. The "smart" Optical Dissolved Oxygen sensor stores calibration and history data within the sensor. This allows you a "plug and play" system.

- Optical Technology without calibration.
- No Drift, Reduced Maintenance
- Stainless Steel (316L) or Titanium Body for Corrosive Applications
- Robust and Waterproof (IP 68)
- Controller with two digital sensor inputs.
- Backlit Display
- Password Protected Access
- Real time clock with Battery backup.

Sensor Specifications (PCOD01 / PCOD02)

Measurement Principle	: Luminescent optical technology
Measurement Range	: 0.00 to 20.00 mg/l or 0.00 to 20.00 ppm or 0.0 to 200 %
Wetted, Body Material	: SS (316L) / Titanium Body
Accuracy	: ± 0.5 %
Resolution	: 0.01 mg/l or ppm
Response Time	: 90% value in less than 60 seconds
Working Temp. Range	: 0 to 50 °C
Max. Pressure	: 5 Bar
Sensor Cable	: Standard 15 Meter

Controller Specifications (PC200)

Measurement	: 2 Nos. ; Digital Sensor Inputs
Display	: Backlit LCD Screen 4*20 Characters ; 5 Directional Keys
Power Requirements	: 110 VAC / 230 VAC ; ± 10 % ; 50 / 60 Hz
Operating Conditions	: -20 to 55 °C
Storage Conditions	: -20 to 65 °C
Analog Output Signal	: 2 Nos. ; 0 / 4-20 mA Isolated ; Max. Load 500 Ohms.
Relays	: 3 Nos. ; Electromechanical SPST ; 6 A ; 250 VAC Max.
Controller Type	: P, PI and ON/OFF Controller
Digital Inputs	: 2 Nos. ; For Pulse Input or Switching Input
Digital Outputs	: 2 Nos. ; Dry Contact Potential Free ; 12 V ; 200 mA
Calibration Methods	: 2 Point Calibration
Memory	: Battery Back up
Enclosure	: IP 65
Enclosure Mounting	: Wall, Panel
Dimensions	: H*W*D (160*165*85)
Weight	: App. 1.1 Kg.

Sensor Dimensional Drawing

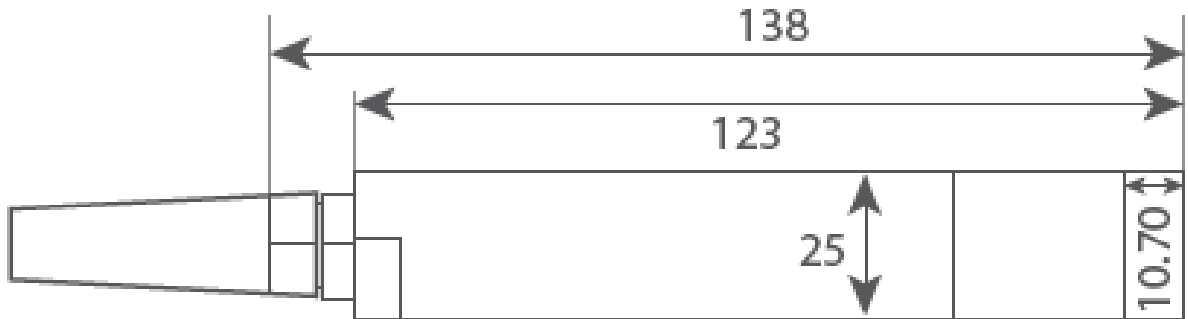

All dimensions are in mm.

Controller Installation Dimension

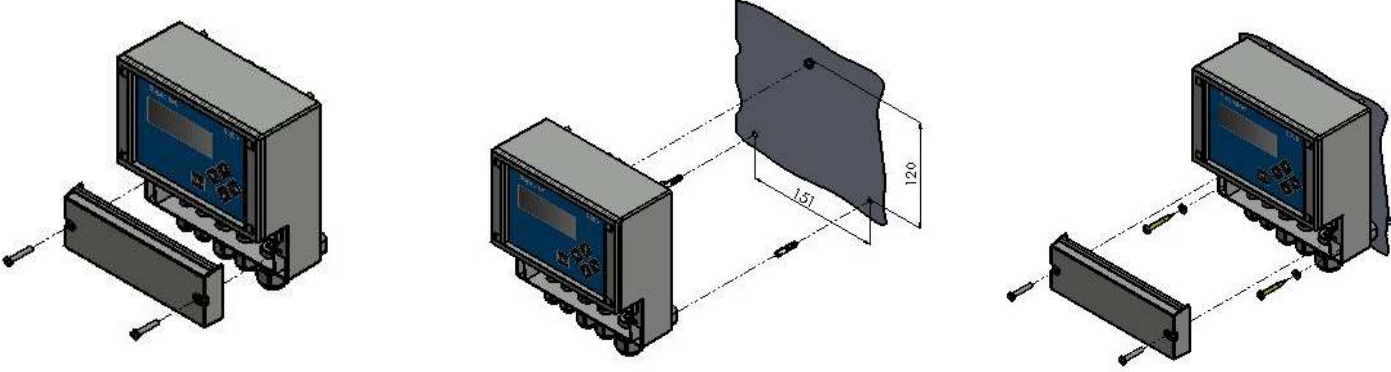

Optical Dissolved Oxygen Sensors with Direct 4 to 20 mA output



Features & Benefits

Potence Controls Optical Dissolved Oxygen sensors measure Dissolved Oxygen with great accuracy in waste water plants. They can connect to any existing measurement systems that accept a 4-20 mA input. This feature reduces the loop cost drastically as you can use any off the shelf Indicator and configure to measure Dissolved Oxygen.

Optical technology is based on the proven method wherein Oxygen concentration is determined by the luminescent quenching of a dye embedded on the sensor surface. Unlike polarographic or galvanic sensor this Optical sensors does not require filling solutions nor a warm up time. Connect it to the indicator and it is up and running within no time.

- Affordable as you do not have to rely on any specific controllers.
- 4-20mA output from sensor enables seamless connectivity to field transmitters or PLC/DCS.
- No electrolyte solution to replenish.
- Replaceable sensor cap.
- No calibration or replacement sensor cap for at least 1 year in most applications.
- Saltwater compensation.
- Sample flow not necessary for measurement accuracy.
- The sensor come with a choice of PVC body or SS 316 body version.
- Sensor cable length up to 100 meters allow flexibility in the field.

Sensor Specifications (PCOD03 / PCOD04)

Wetted Material	: PVC or SS body
Measurement Range	: 0-20 ppm, 0-200% Saturation
Accuracy	: + /- 0.1 ppm below 1 ppm : + /- 0.2 ppm above 1 ppm + /- 1% Of reading
Resolution	: 0.1 ppm
Response Time	: T90 < 40 Seconds
Salinity Compensation	: Provided
Input Power	: 24VDC
Output Signal	: 4-20 mA
Sensor Cable	: 6 mtr. (optional cable length available up to 100 Meters)
Connections	: 1"NPT(M) front and back fittings
Op. Temp.	: - 5 to 50 °C

Controller Specifications (PC500)

Display	: Seven Segment LED Display
Power Requirements	: 90- 270 VAC ; 50 / 60 Hz
Analog Output Signal	: 4-20 mA ; Max. Load 600 Ohms
Analog Output Function	: Retransmission
Relays	: Electromechanical SPDT ; 10A ; 115 / 230 VAC
Relays Operational Mode	: Control
Enclosure	: ABS
Enclosure Rating	: IP 54
Enclosure Dimension	: H*W*D (48*96*75) mm
Cut-Out	: 44*92 mm

General Arrangement



Ordering Information

Model Number :

PCODO1 : Optical Dissolved Oxygen Sensor ; SS Body ; Range : 0.00 to 20.00 mg/l or 0.00 to 20.00 ppm or 0.0 to 200 % ; 15 Meter Cable. (Works with PC200 Controller)

PCODO2 : Optical Dissolved Oxygen Sensor ; Titanium Body ; Range : 0.00 to 20.00 mg/l or 0.00 to 20.00 ppm or 0.0 to 200 % ; 15 Meter Cable. (Works with PC200 Controller)

PC200 : Dissolved Oxygen Controller ; 110 /230 VAC ; 4-20 mA Output ; Relays

PCODO3 : Optical Dissolved Oxygen Sensor ; SS Body ; Direct 4 to 20 mA Output ; Range : 0 to 20.00 ppm ; 6 Meter Cable. (Works with PC500 Indicator / Any other PLC)

PCODO4 : Optical Dissolved Oxygen Sensor ; PVC Body ; Direct 4 to 20 mA Output ; Range : 0 to 20.00 ppm ; 6 Meter Cable. (Works with PC500 Indicator / Any other PLC)

PC500 : Dissolved Oxygen Indicator ; 110 /230 VAC ; 4-20 mA Output ; Relay

In the interest of improving and updating, PCPL reserves the right to alter specifications at any time.